



Main features

- Range of measurement: from 500 to 10.000 Kg
- Accuracy class: D1 (OIML R60)
- All stainless steel construction
- Corrosion resistant
- Insensitive to lateral loads
- Grade of protection: IP66 (DIN 40050)

The principle of measurement of the SH series load cells is the deformation caused by the shear generated by the applied load. The result is a transducer that is extremely rigid both for the measured load and of lateral or transverse loads which have little effect on it.

The high degree of accuracy, good level of thermal compensation, the grade of protection make the SH series load cells safe for use in the most severe conditions.

TECHNICAL DATA

Accuracy (OIML IR60)	D1
Divisions	1000
Nominal full scale load (Ln)	500...10.000 Kg
Nominal output at FSO	2mV/V
Output tolerance at Ln	< ± 0,2% FSO
Combined errors: Non linearity Hysteresis, Repeatability	< ± 0,05% FSO
Creep (after 30 min. at Ln)	< ± 0,05% FSO
Zero load out of balance signal	< ± 1% FSO
Calibration signal *	80%FSO ± 1%
Thermal drift in compensated range	Sensitivity Zero Calibration
	< ± 0,005% FSO/°C < ± 0,01% FSO/°C -
Nominal input resistance	350 Ohm
Nominal output resistance	350 Ohm
Isolation resistance	> 10 GOhm
Nominal supply voltage	10 V
Maximum supply voltage	15 V
Compensated temperature range	-10...+40°C
Maximum temperature range	-20...+60°C
Storage temperature range	-30...+80°C
Permitted static load	130% Ln
Maximum applicable load	150% Ln
Rupture load	> 300% Ln
Maximum elastic deformation at Ln	< 0,7 mm
Grade of protection (DIN40050)	IP66
Electr. connections screened cable	4x0,25 / 5 m.
Elastic element material	Stainless steel

* The combined errors and thermal drift of sensitivity are within the framework defined by the OIML IR60

MECHANICAL DIMENSIONS

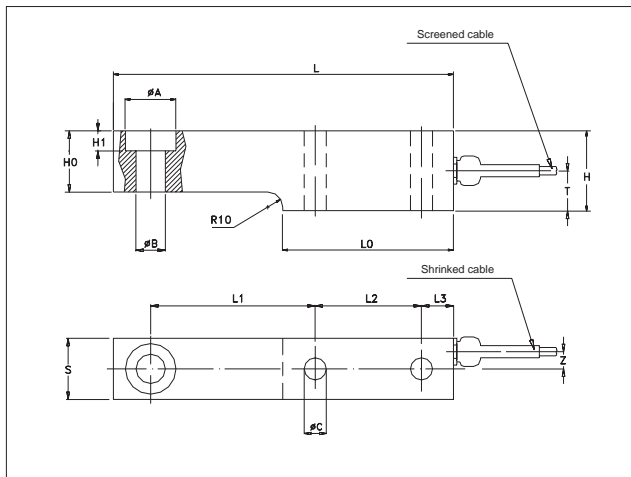

Ln (Kg)

	500/1000/2000	5000/7500	10000
ø A	30,2	41,3	51
ø B	17,5	25,5	32
ø C	13,2	22,5	27
H	47,6	70	82,6
H0	36,5	47,8	63,5
H1	11,9	15,9	20,7
L	203,2	235	279,4
L0	102	118	140
L1	98,3	123,7	139,7
L2	63,5	66,5	82,6
L3	19,1	20,6	25,4
S	36,5	47,6	60,3
T	23,8	46	51
Z	10,25	16	21
Nm*	135	660	1150

Dimensions mm. (± 0,1)

Recommended torque with UNI 5931 screws of resistance class 10.9 according to UNI 3740

ELECTRICAL CONNECTIONS

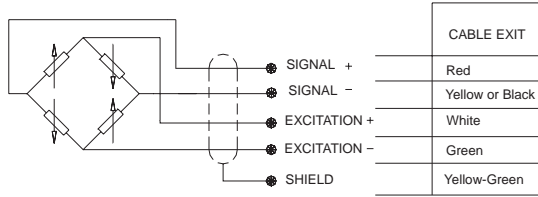

4x0.25 Screened cable

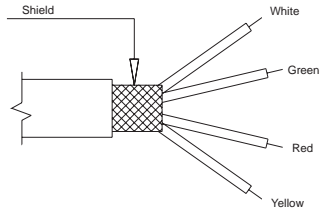

* The screen is isolated from the transducer body. It is recommended that the ground is connected at the instrument end.

Cells connected in parallel

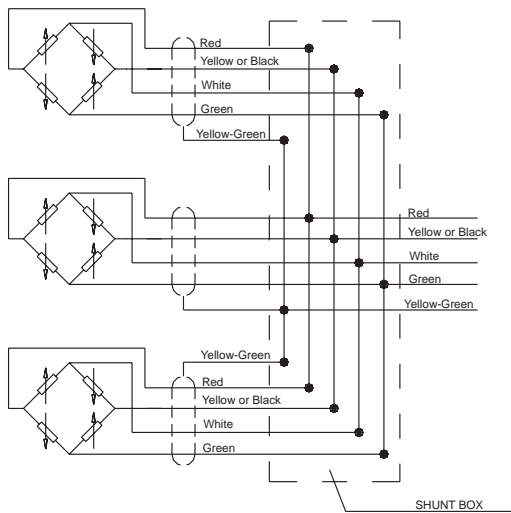

In systems that use several cells, the parallel connection automatically sums the loads on each individual cell.

Using this method of measurement, the maximum load will be the sum of the loads on the individual cells and the sensitivity will be the average value of these cells. It is important that the user ensures that no cell is stressed beyond its maximum rating under any load condition.

CONVERSION TABLE

Kg	N	Lb
1	9.807	2.205
0.102	1	0.225
0.454	4.448	1

GEFRAN spa reserves the right to make any kind of design or functional modification at any moment without prior notice.

OPTIONAL ACCESSORIES

ORDER CODE

Load cell

SH

MEASUREMENT RANGE (Kg)

0 - 500	K5C
0 - 1000	K1M
0 - 2000	K2M
0 - 5000	K5M
0 - 7500	K7.5M
0 - 10000	K10M

If request, it is possible to supply models with non-standard mechanical and/or electrical features.

Ex.: SH - K10M

SH load cell, measurement range 0 - 10.000 kg.