

### Main characteristics

- Absolute transducer
- Contactless transducer for longer lifetime
- Strokes from 50 to 4000 mm
- Quick plug-in through stainless steel connectors
- Sliding or floating magnetic cursor
- Synchronous Serial Interface direct to controllers
- Resolution from 2 to 40  $\mu\text{m}$
- Data format: binary or Gray code; incremental/ decremental
- Work temperature:  $-30...+75^{\circ}\text{C}$
- Resistance to vibration (DIN IEC68T2/6 12g)
- IP67 protection
- EMI CE compatibility (EN 50081-2 50082-1)
- EMI CE compatibility 24Vdc  $\pm 20\%$

Contactless magnetostriuctive linear position transducer with RS422-SSI digital output interface. The absence of electrical contact on the cursor eliminates all wear and guarantees almost unlimited life. Compact size for simple installation. Full protection against outside agents for use in harsh environments with high contamination and presence of dust. Excellent linearity, repeatability, resistance to mechanical vibrations and shocks.

### TECHNICAL DATA

Model	from 50 to 4000 mm
Measurement taken	displacement
Position read sampling time (typical)	1 ms
Shock test DIN IEC68T2-27	100g - 11ms - single shock
Vibrations DIN IEC68T2-6	12g / 10...2000Hz
Displacement speed	$\leq 10$ m/s
Max. acceleration	$\leq 100$ m/s <sup>2</sup> displacement
Resolution	2, 5, 10, 20, 40 $\mu\text{m}$
Cursor	Sliding cursor Floating separate cursor
Working temperature	$-30...+75^{\circ}\text{C}$
Storage temperature	$-40...+100^{\circ}\text{C}$
Coefficient of temperature	20 ppm FS / $^{\circ}\text{C}$
Protection	IP67

### ELECTRICAL DATA

Output signal	Synchronous Serial (SSI); Binary/Gray; Incremental/Decremental
Data length	24 - 25 bit
Nominal power supply	24 Vdc $\pm 20\%$
Max. power ripple	1Vpp
Max. input	100mA
Output load	RS422/485 standard
Electrical isolation	500V (D.C. supply/earth)
Protection against polarity inversion	Yes
Protection against overvoltage	Yes
Self-resetting internal fuse	Yes

### MECHANICAL DIMENSIONS

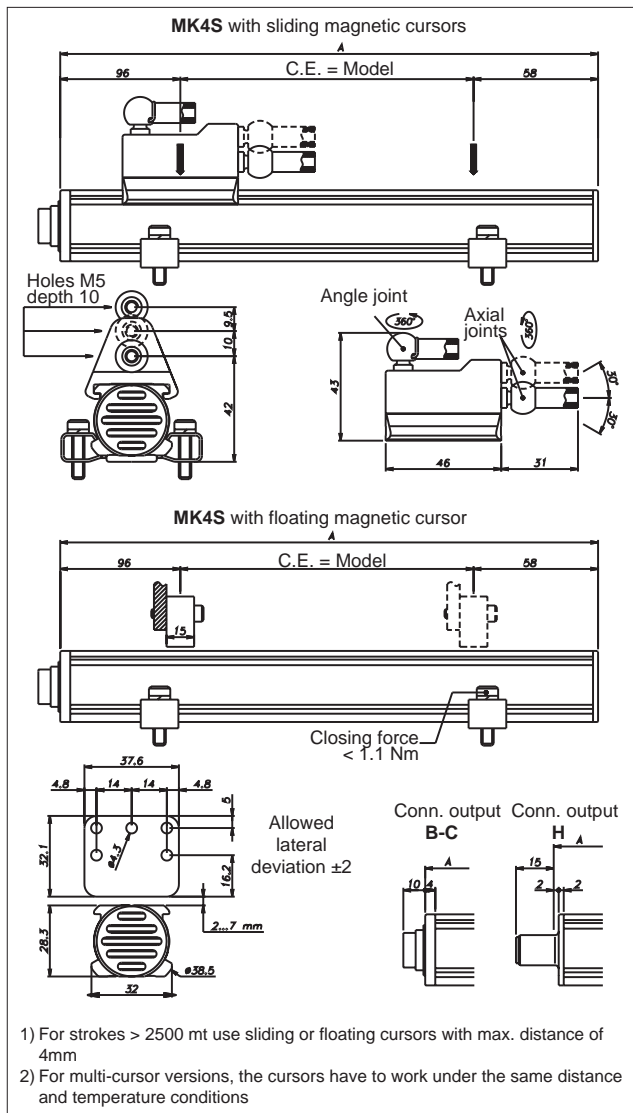

## ELECTRICAL / MECHANICAL DATA

Model	50 75 100 130 150 175 200 225 250 300 350 360 400 450 500 550 600 650 700 750 800 850 900 950 1000 1100 1200 1250 1300 1400 1500																			
	1750 2000 2250 2500 2750 3000 3250 3500 3750 4000																			
Electrical stroke (E.S.)	mm	<b>Model</b>																		
Independent linearity	± %F.S.	typical 0.02 (Max. 0.04)																		
Max. dimensions (A)	mm	<b>Model + 154</b>																		
Repeatability	mm	< 0.01																		
Hysteresis	mm	< 0.01																		
Sampling time	ms	<b>0,5 (1 for stroke from 300 to 1100) (1,5 for stroke from 1100 to 2000) (2 for strokes &gt;2000) (3 for strokes ≥ 3000)</b>																		

## ELECTRICAL CONNECTIONS

**OUTPUT MK4S B**

**OUTPUT MK4S C**

**OUTPUT MK4S H**

**OUTPUT MK4S F**

Function	MK4S B	MK4S C	MK4S H	MK4S F
	6-pin M16	8-pin M16	8-pin M12	Cable output
Data -	1	5	5	Orange
Data +	2	2	2	Orange / White
Clock +	3	1	3	Green / White
Clock -	4	3	1	Green
Power supply +	5	7	7	Blue / White
Power supply GND	6	6	6	Blue
n.c.	-	8	8	-
n.c.	-	4	4	-

MK4S H
<i>With optional 8-pin cable</i>
Green
Gray
Pink
Yellow
Brown
Blue
White
Red

The transducer case must be grounded with the cable sheathing on the control system side only.

## SYNCHRONOUS SERIAL OUTPUT MK4 SSI (Description)

The diagram illustrates the operation of an MK4 S sensor with Synchronous Serial Interface SSI.

Magnet position on the sensor is determined by the magnetostrictive system.

The shift signal is supplied in binary or Gray Code at 24-25 bits and transmitted to the controller via SSI interface.

The refresh rate can reach up to 2000 measurements per second (depending on length).

In addition, the output is absolute, assuring that information on magnet position are immediately available even when the system is switched on.

### BLOCK DIAGRAM

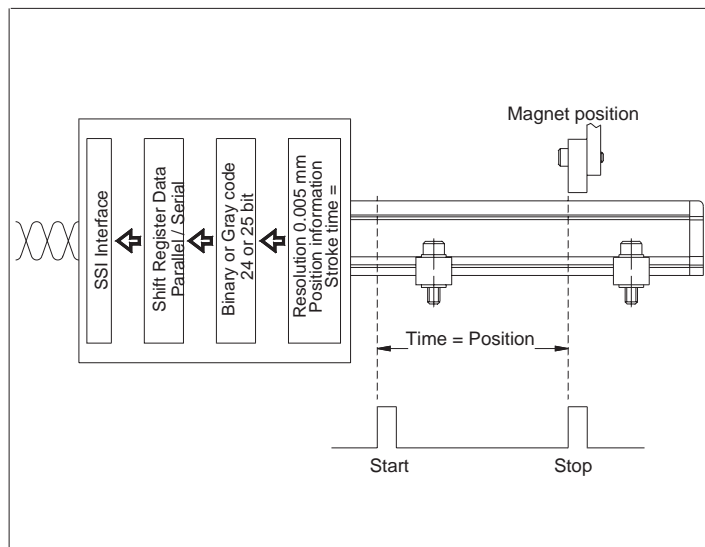

## DATA FORMAT

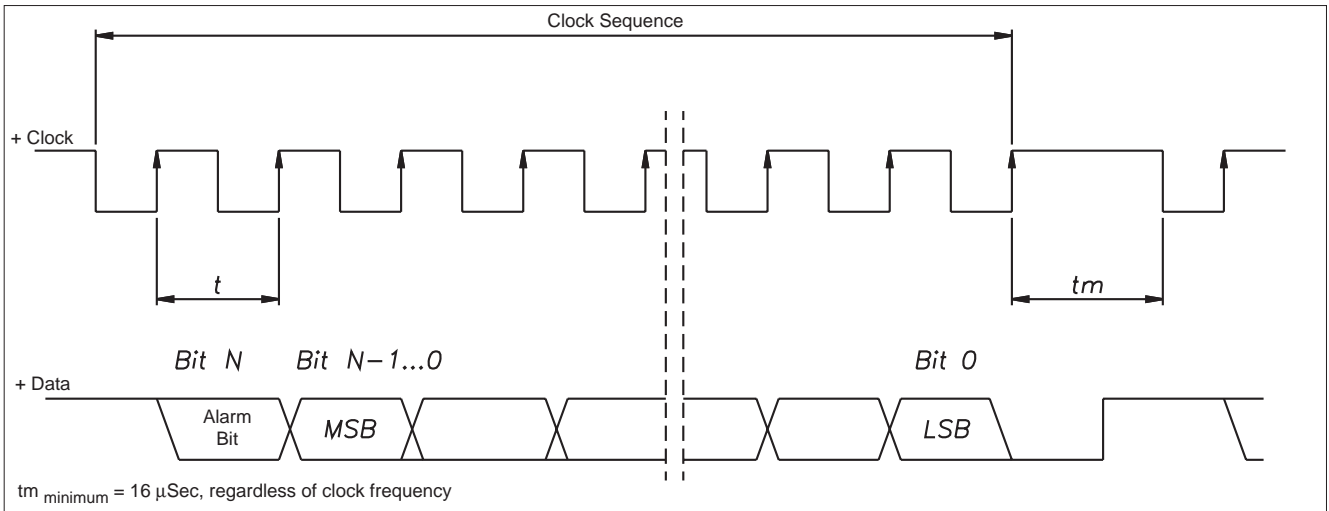

## ERROR MESSAGES

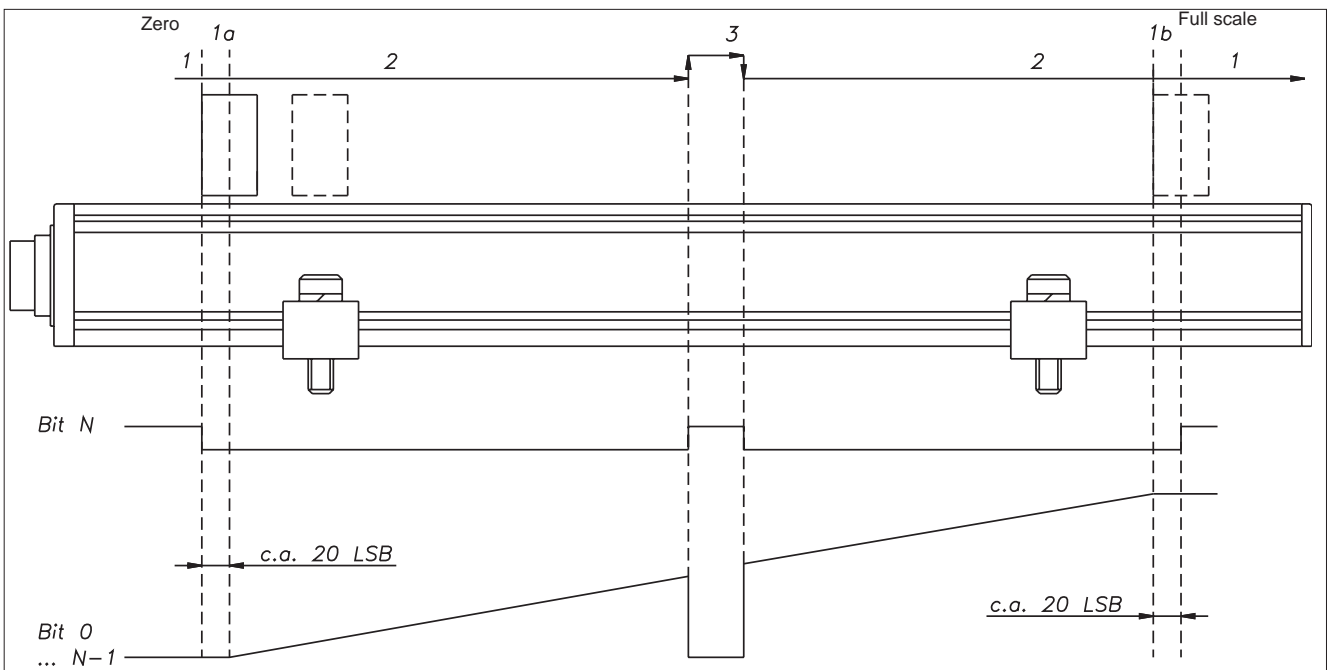

Magnet position	Bit N	Bit N-1...0
1: Outside measurement range	1	0
1a: Outside measurement range	0	0
1b: Outside measurement range	0	Full scale
2: Inside measurement range	0	Prop. to dist.
3: Magnet not present	1	0

## SYNCHRONOUS SERIAL OUTPUT MK4 SSI (input/output Synchronization Option)

### SYNCHRONOUS SERIAL OUTPUT MK4 SSI (SYNCHRONIZED VERSION)

Magnet position on the sensor is determined by the magnetostrictive system.

In this case, internal sample rate is synchronized with the SSI external enquiry rate coming from the control.

The shift signal is supplied in binary or Gray Code at 24 bits and transmitted to the controller via SSI interface.

The output is absolute, assuring that information on magnet position are immediately available even when the system is switched on.

The Synchronous Serial Interface SSI is commonly used as an interface between an absolute position sensor and a controller.

The SSI uses a pulse train to initialize the sensor output.

Position data are continuously updated and made available in the shift register.

To maintain synchronism between the internal and external sample rate, the refresh rate can vary from a minimum of 2 KHz (for strokes up to 750 mm) to a maximum of 125 Hz.

The minimum sample rate time can be optimized for shorter strokes.

The data transmitted when the sensor receives the pulse train from the controller refer to the internal sampling just ended.

In case of lack of cursor or measurement error, all 24 bits are set to zero.

## SYNCHRONOUS SERIAL OUTPUT MK4 SSI (Oversampling Option)

Magnet position on the sensor is determined by magnetostrictive technology.

The internal sample rate of the position can vary from 2 KHz to 500 Hz according to the stroke. The shift signal is supplied in binary or Gray Code at 24 bits and transmitted to the controller via SSI interface. The output is absolute, assuring that information on magnet position are immediately available even when the system is switched on. Normally, when data are available, they are transmitted to the SSI shift register, where they are available to the controller. Therefore, the refresh rate of the shift register is the same as the internal sample rate. In the "oversampling" version, the transducer's electronics synchronize with the frequency of the external SSI clock, and adjusts the internal timings before every external enquiry. The supplied data is calculated by a first level interpolation, and equals:

$$\text{Out} = M + V * T$$

M = last internal measurement

V = magnet speed

T = time elapsed since last measurement

The data is supplied to the shift register taking account of any Jitter in the sampling time of the controller (considered to be 40 µSec). Lower Jitter values guarantee better interpolation results (Figure 1). To maintain synchronization between SSI clock and shift register refresh, the sample frequency can vary from a minimum of 5.5 KHz to a maximum of 125 Hz. Typical value considered = 4KHz.

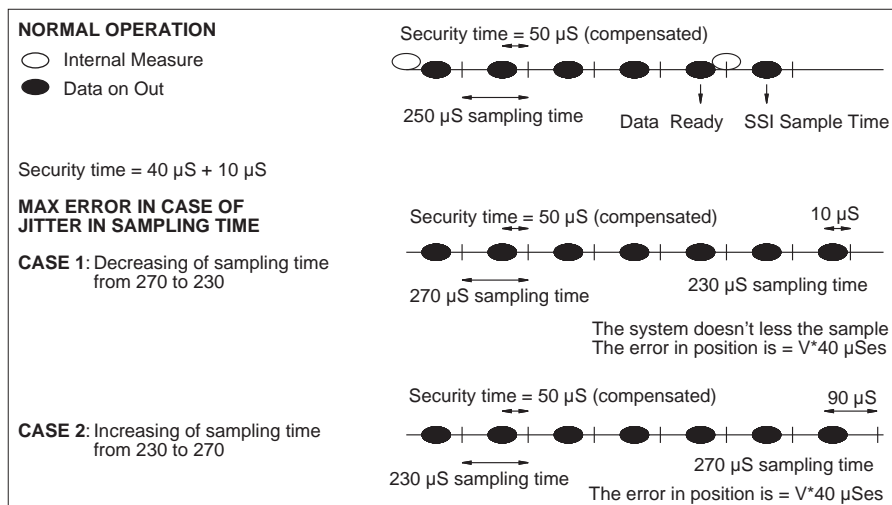

Figure 1

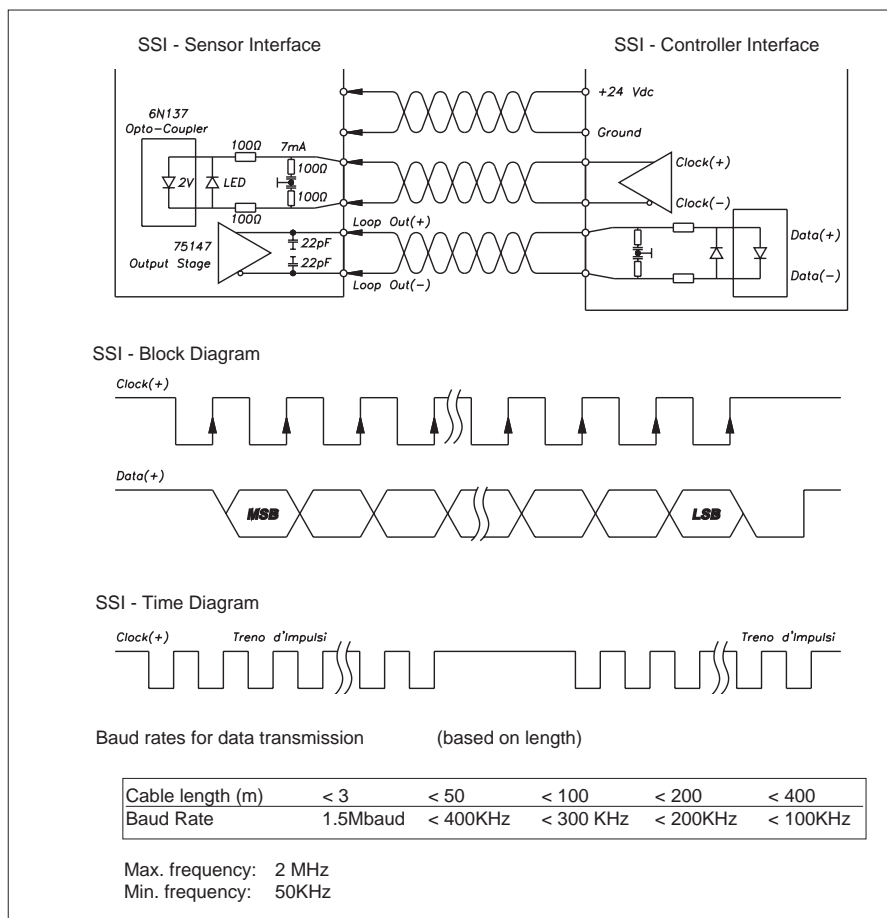

Figure 2

# ORDER CODE

Position transducer

M K 4 S B

SSI digital output S

**Connector**

DIN45322 6-pin connector output	B
<i>Available on request</i>	
DIN45326 8-pin connector output	C
M12 8-pin connector output	H
Cable output PVC 6-pin (1 meter)	F

**Model**

**Output**

Binary data code output	B
Gray data code output	G

**Data length**

Data length 24 bit	3
Data length 25 bit	4

0 0 0 0 X X X X X 0 X X

**System resolution**

0.002 mm	0
0.005 mm (standard)	1
0.010 mm	2
0.020 mm	3
0.040 mm	4

**Scale orientation**

Ascending (standard)	1
Descending	2
Ascending (synchronized) (*)	3
Descending (over sampling refresh output 4 KHz)	4

(\*) = See supplemental data

**Outputs**

B, C, H Outputs	00
<b>F outputs cables length</b>	
1 meter (standard)	00
2 meters	02
3 meters	03
4 meters	04
5 meters	05
10 meters	10
15 meters	15

Ex.: MK4-S-B-0400-B-3, 0000-X-X-1-1-X-00-X-0-XX

Transducer model MK4, SSI output, connector B, model 400, binary data code output, data length 24 bit, system resolution 0.005mm, scale orientation ascending

Mechanical and/or electrical characteristics differing from those in the standard version may be arranged on request

GEFRAN spa reserves the right to make aesthetic or functional changes at any time and without notice

## CURSORS ON REQUEST

P C U R    0 1

Cursors	
Sliding cursor, axial joint (low) (STANDARD)	035
Sliding cursor, axial joint (high)	036
Sliding cursor, angle joint	037
Floating cursor	034
Number of cursors	

PCUR035

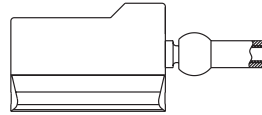

PCUR036

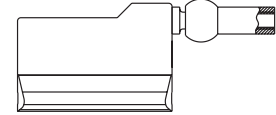

PCUR037

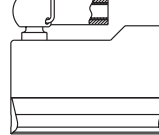

PCUR034

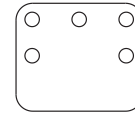

## BRACKETS ON REQUEST



P K I T    0 1

Attachment brackets	
Stainless steel bracket, center distance 42.5mm	090
Stainless steel bracket, center distance 50mm	091
Number of brackets	

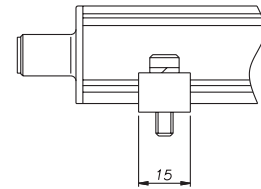
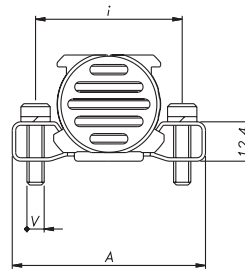

Brackets code	Center distance (i)	Screw (V)	Dimensions (A)
PKIT090	42.5	M4	56
PKIT091	50	M5	63.5

## OPTIONAL CONNECTORS

For output H, M12 connector thread

Codes: **CON035** for 8-pin output (MK4S H)  
**CON042** for 8-pin output (MK4S H)

For outputs B-C, M16 connector thread

Codes: **CON021** for 6-pin output (MK4S B)  
**CON022** for 6-pin output (MK4S B)  
**CON023** for 6-pin output (MK4S B)  
**CON026** for 8-pin output (MK4S C)  
**CON027** for 8-pin output (MK4S C)  
**CON028** for 8-pin output (MK4S C)

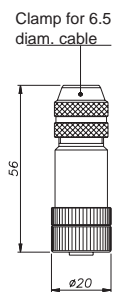

CON035  
IP67 - IEC 48B

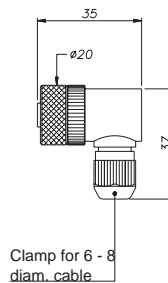

CON042  
IP67

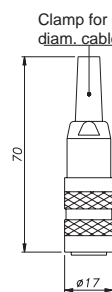

CON021  
CON026  
IP40 - EMC

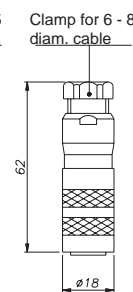

CON022  
CON027  
IP67 - EMC

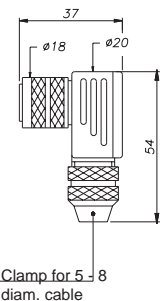

CON023  
CON028  
IP67 - EMC

Connector extraction length 10 mm

## OPTIONAL CABLES OUTPUT H

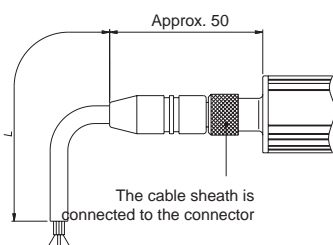

PREWIRED CABLE WITH STRAIGHT CONNECTOR

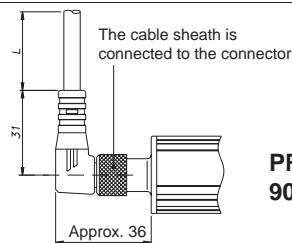

PREWIRED CABLE WITH 90° CONNECTOR

Code for 8-pin cable		MK4S - H	
Length "L"		CODE	
		Straight cable	90° cable
2	mt	CAV002	CAV005
5	mt	CAV003	CAV006
10	mt	CAV004	CAV007
15	mt	CAV009	CAV008

GEFRAN spa  
via Sebina, 74  
25050 PROVAGLIO D'ISEO (BS) - ITALIA  
ph. 0309888.1 - fax. 0309839063  
Internet: <http://www.gefran.com>

**GEFRAN**

MK4S - 07/04